

"SUPER DOME"

Hi-Res Varifocal "Full Size" Dual Voltage Dome



The "Super Dome" from Rugged CCTV is the most incredible value we've ever offered in an Indoor Dome.

This camera features a 1/3" Sony Super HAD CCD that has 480 Lines of Resolution, Low Light handling of 0.1 Lux, and a 3.5mm to 8mm Varifocal Lens with Auto-Iris and Auto White Balance and Gain Control.

The "Super Dome" is Dual Voltage (12V DC or 24V AC) and uses about 150mA of Power

Black Case

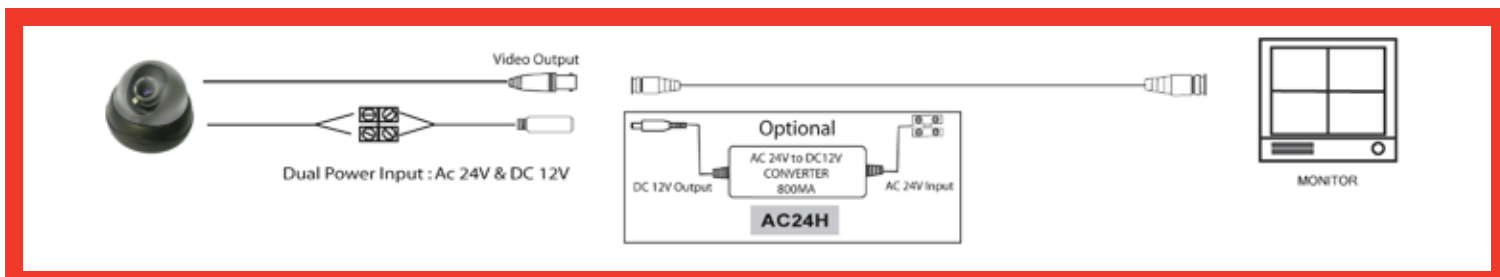

| | |
|------------------------|---------------------------------------|
| | Model #: RI-SuperDome |
| Type | Color Dome Camera |
| Pick-Up Device | 1/3" Sony CCD Image Sensor |
| Picture Elements H x V | NTSC: 512 x 492 - PAL: 512 x 582 |
| Horizontal Resolution | 480 Lines |
| Vertical Frequency | NTSC: 59.94Hz - PAL: 50Hz |
| Scanning System | 2:1 Interlace |
| Mini Illumination | 0.1 Lux Day & Night |
| Synchronization | Internal |
| S/N Ratio | >48dB |
| Electronic Shutter | Up to 1/100,000 sec |
| White Balance | Auto White Balance |
| Lens | 3.5-8mm F1.6 Auto Iris |
| Gamma | 0.45 |
| Video Output | 1Vp-p, 75 Ohms |
| Auto Gain Control | Auto |
| Power Supply | Dual Power: AC 24V & DC 12V (+/- 10%) |
| Power Consumption | 150mA (+/- 10%) |
| Color | Black |
| Weight | 1.5lb - 680g |
| Storage Temperature | -22°F to 140°F |
| Operating Temperature | 14°F to 122°F |

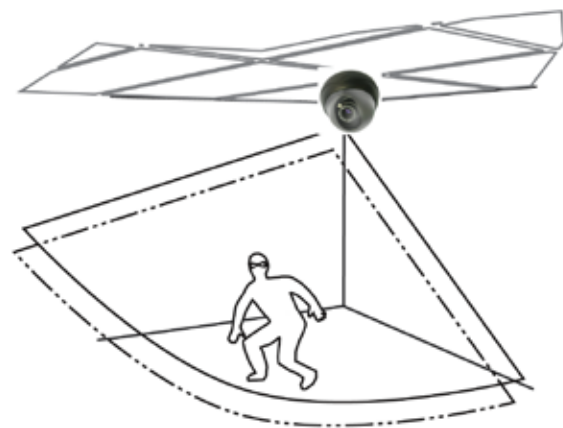

5327 Cedar Creek Drive
 Kemp, Texas 75143
 Toll Free: 866-301-CCTV
 Phone: 903-498-3240
 Fax: 903-498-8989
www.rugged-cctv.com