

SUPER INFRARED

MODEL#: 550RBINF

- Day/Night camera with SONY 1/3" Super HAD CCD sensor
- Horizontal Resolution of 520 TV Lines
- More than 30m/90' IR Distance
- Built-in 5-50mm DC Auto Iris Day and Night Lens
- External lens adjustment
- IR LEDs 12 Total
- IR Beam Reflection Protector
- Weatherproof grey aluminum housing with Sun-Shield Cover (IP66)
- Furnished with DC power cable and video cable
- 12V DC operation• Cable managed bracket



Model: 550RBINF	NTSC	PAL
Total Pixels	811(H) x 508 (V)	795 (H) x 596 (V)
Effective Pixels	768 (H) x 494 (V)	752 (H) x 582 (V)
Image Sensor	1/3" Sony Super HAD CCD	
Scanning System	Interlaced	
Frequency	Horizontal: 15.734Khz Vertical: 59.94Hz	Horizontal: 15.625Khz Vertical: 50.00Hz
Horizontal Resolution	More than 520 TV Lines	
Video Output	1.0Vp-p / 75Ω	
S/N (Y signal)	48dB (AGC OFF)	
Min. Illumination	0.3 Lux / F1.2(color), 0.1 Lux / F1.2 (B/W)	
White Balance	ATW	
Shutter Speed	1/60~1/100,000 NTSC, 1/50~1/100,000 PAL	
Backlight	ON / OFF (DIP SW Select)	
Flickerless	ON / OFF (DIP SW Select)	
AGC Control	ON / OFF (DIP SW Select)	
Lens Mount	5~50mm DC Varifocal Lens	
IR Range	98ft	
LED Quantity	12pcs (10pie LED)	
Supplied Voltage	12V (Recommendation 12.0V ± 0.5V)	
Power Supply	12V DC / 140mA (Max 1.7W) (CDS ON: 600mA Max)	
Operating Temperature/ Humidity	14°F ~ 144°F / 10 ~ 85% RH	
Dimensions	12.20 x 4.02 x 9.21 inches	
Weight	Approx 3.31lbs.	

Dimensions

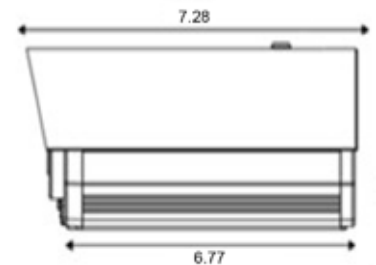
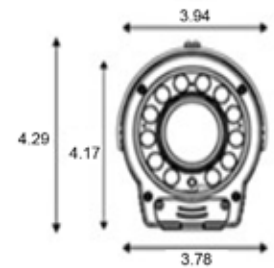

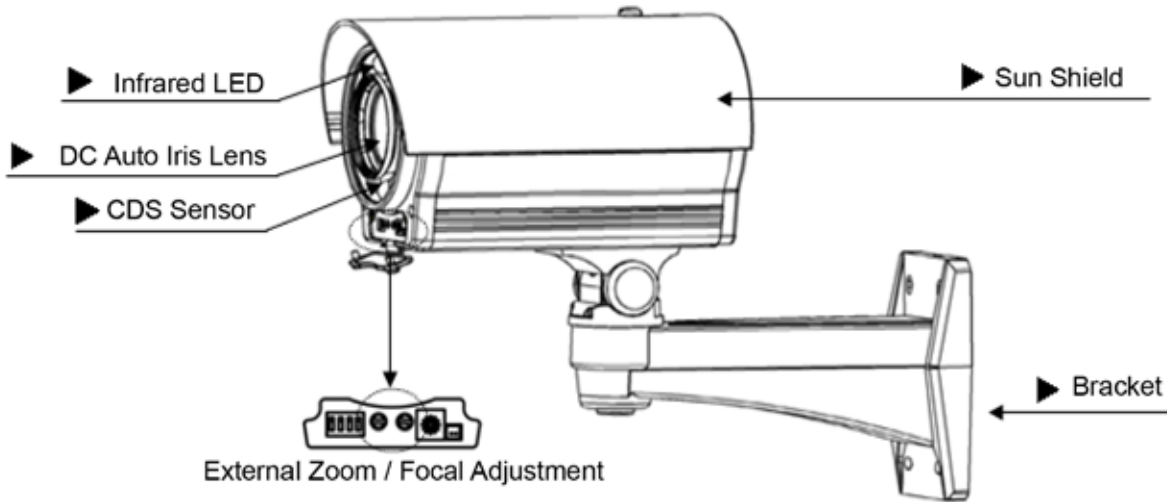

Mounting

